

## **Chapter 6: Predicting Future Demand in England, a Simulation Model of Renal Replacement Therapy**

Dr Paul Roderick, Senior Lecturer in Public Health Medicine, Southampton University

Dr Ruth Davies, Senior Lecturer, School of Management, Southampton University

Mr Chris Jones, Research Fellow, Health Care Research Unit, Southampton University

Professor Terry Feest, Consultant Nephrologist, Southmead Hospital, Bristol

Dr Steve Smith, Consultant Nephrologist, Birmingham Heartlands Hospital, Birmingham

Dr Ken Farrington, Consultant Nephrologist, North Herts Hospital Trust, Stevenage

This chapter is based on a study funded by the Department of Health. A full report has been submitted and, once agreed, will be available. This will contain all the working papers and appendices, as well as a more detailed explanation of the model.

### **Summary**

- A discrete event simulation model has been developed to model the future demand for renal replacement therapy in England. The data used to populate the model are largely derived from the UK Renal Registry and UK Transplant. The model describes the transitions between modalities and takes account of unmet need for renal replacement therapy, the impact of changing demography and diabetes incidence, transplant supply, and patterns of use and outcomes of renal replacement therapy.
- The predicted number on renal replacement therapy will continue to rise for 20 years until a steady state position has been reached, with a future prevalence approaching 60,000 patients. By 2010, the current prevalence will have increased from about 30,000 to between 42,000 and 51,000, depending on assumptions about acceptance rate and patient survival. Much of the rise in demand will occur even if there is no increase in the current acceptance rate. This growth will occur disproportionately in the elderly treated by haemodialysis. The most realistic figures are over 45,000 patients (900 pmp), or a 4.5% average annual increase over the decade.
- More work is required to investigate the cost of renal replacement therapy, and the model's estimates will need to be revised as new data emerge on patterns of acceptance, transplant supply and patient and mode survival. The potential demand for renal replacement therapy highlights the importance of addressing the prevention of chronic kidney disease.

### **Background**

The main driver to growth of the renal replacement therapy (RRT) programme has been a rising acceptance rate. This was only 20 per million population (pmp) in 1982 but has reached over 93 pmp in 2001.<sup>1,2</sup> An increasing proportion of these patients are elderly, the median age being over 65 in 2000, and many patients have associated comorbidity such as cardiovascular disease.

The current acceptance rate is, however, lower than that of many Western countries; it should be higher to cover the assumed unmet population need, which is largely found in the elderly and in patients with comorbidity. Future need will also be influenced by demographic change, particularly in terms of the ageing of ethnic minority populations,<sup>3,4</sup> which have a higher rate of established renal failure (ERF). There is, in Europe and the USA, an epidemic of type II diabetes, which may lead to a higher incidence of diabetic ERF<sup>5</sup> in the future despite therapeutic advances in preventing diabetic nephropathy.

Davies and Roderick<sup>6</sup> have reported results from a simulation model, using a variant of discrete event simulation called POST.<sup>7</sup> This used data collected from the first National Renal Review in 1991–93. It showed that, from 1991/92, based on an acceptance rate of 80 pmp, the steady state would not be reached for 20 years or more, and the final steady prevalence rate might be twofold higher, at 800 pmp.<sup>6</sup> Key determinants of the predicted growth were patient survival and acceptance rate. Transplant supply determined the dialysis to transplant ratio and hence the overall projected cost of the programme. The use of the model was, however, limited by the availability of data at the time; it was, for example, not possible to separate the types of dialysis despite the significant organizational and resource differences between them.

There have been significant changes in the pattern of modes of treatment in recent years.<sup>1,8</sup> Although there are almost as many patients with functioning grafts as with dialysis, the availability of cadaver kidney donors has been falling, leading to an increase in the transplant waiting list.<sup>9</sup> UK Transplant (UKT) is, however, addressing the problems of this shortage.<sup>10</sup> Measures have been instigated to improve the situation for both cadaver and live organs. The effects of achieving such targets need to be evaluated.

Peritoneal dialysis (PD) was the mainstay of the expansion in dialysis in the 1980s, but haemodialysis (HD) is now the most common option.<sup>8</sup> The fastest growth in recent years, in both absolute and relative terms, has been in hospital HD, particularly as delivered in renal satellite units.<sup>11</sup> There is a need to take patient choice of mode into account.<sup>12</sup>

The Renal Association Standards document, continuing an audit by the UK Renal Registry, the forthcoming National Service Framework and initiatives by UKT, should bring about changes in patterns of treatment and improvements in patient survival to a level comparable with that of other European countries.<sup>13,14</sup> This will increase the prevalence of patients on RRT but may be partly offset by accepting more patients who are older, with associated comorbidity, and who are therefore likely to have a poorer survival.

The earlier simulation model has been rewritten to provide a Windows interface, now takes account of transitions between PD and HD and includes live transplantation. The use of this model provides more robust estimates of the likely growth of the RRT programme and the effect of different scenarios.

This chapter presents a development of the original model and an assessment of the impact on patient numbers of:

- a rising acceptance rate, including the effect of demographic change using national population projections in England 2000–10 and specifically change in the ethnic minorities and potential increases in diabetic ERF;
- the effect of an increasing cadaveric and live donor organ supply;
- the balance of the use of HD and PD, given patient choice;
- increasing patient survival on RRT.

A report containing full details of the work, including appendices and supporting working papers, is available from the authors ([pjr@soton.ac.uk](mailto:pjr@soton.ac.uk)).

## **Methods**

The methods are explained in the full report.

### ***Simulation model***

#### ***Risk groups***

The discrete event simulation describes the flow of patients between states, a flow that is dependent on the patient's risk factors. We chose to use 14 risk groups: seven age groups together with the presence or absence of diabetic ERF. Patients over the age of 16 were divided into 10 year age groups up to 75+. Comorbidity is an important factor in the survival of patients on RRT, but these data are currently incomplete from UK Renal Registry, so the presence of diabetes as a cause of renal disease has been used as a proxy. One further possibility was to subdivide the population by ethnic group. Diabetic ERF and hypertension are more common in certain ethnic minorities, and one might therefore assume that these groups have a poorer outcome on RRT. There is some evidence for this in US Blacks but limited UK data as yet. To keep the model simple, we have not stratified by ethnicity, although the change in the population and differential pattern of diabetic ERF by ethnic group are taken into account.

#### ***Patient flow through the model***

Figure 6.1 shows the flow of patients through the model. Incident patients enter the model at the point in time at which they need RRT. Prevalent patients are allocated to their current treatment mode. The time spent in each state is determined by samples from patient and mode survival distributions. When a patient receives a transplant, he or she is removed from dialysis and the survival distributions are re-sampled. When a graft fails, the patient returns to dialysis, the mode being based on probabilities derived from Renal Registry data in 2000.

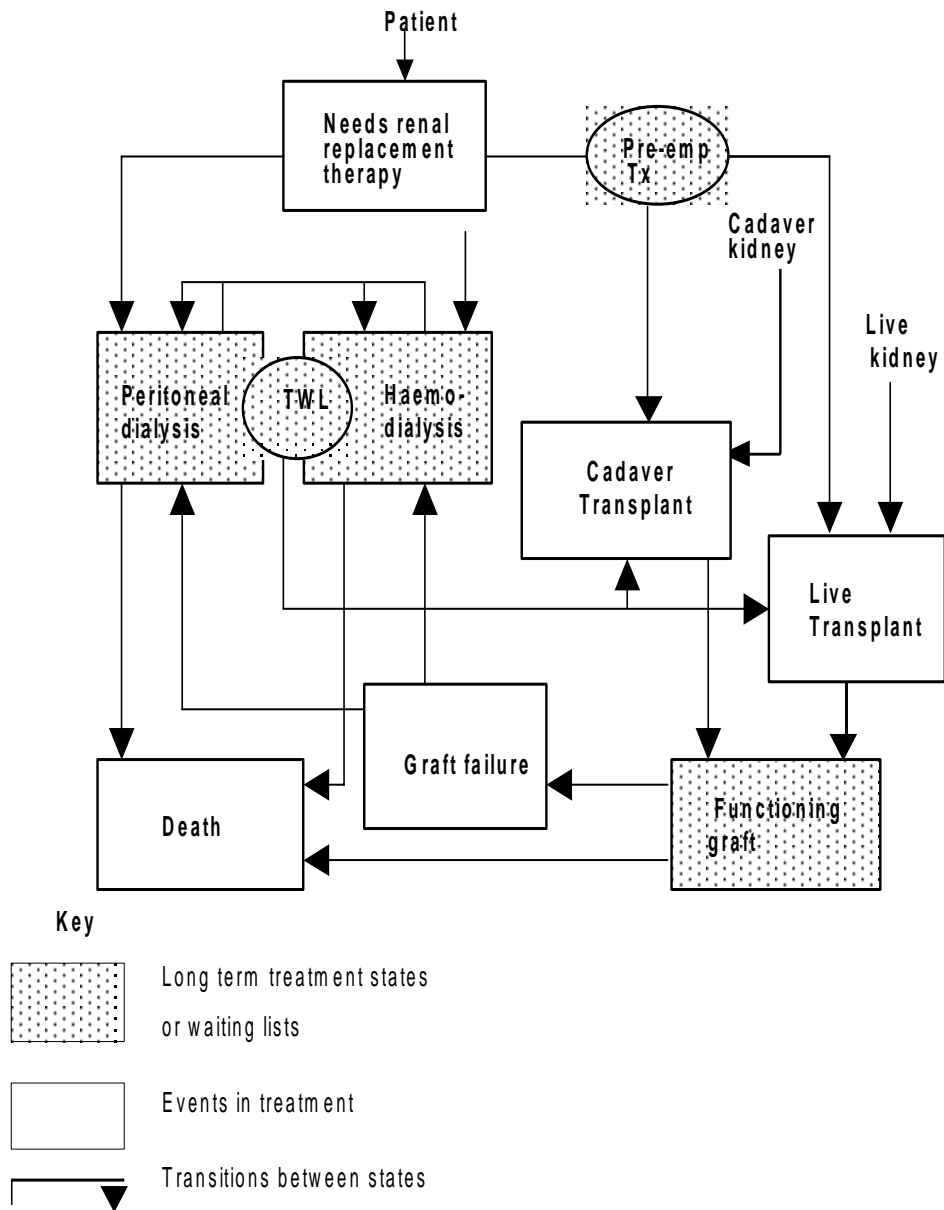

**Figure 6.1: Schematic diagram of the flow of patients through the mode**

Note: The model does not currently allow for pre-emptive live transplantation.

### **Simulation output**

The user can specify the number of simulated years, the time intervals at which information is made available and the number of iterations. The programme collects information on patient activities as the simulation progresses and averages the results over all iterations. The output data, by time interval, are as follows:

- average patient numbers on HD, PD, functioning cadaver graft, functioning live graft and transplant waiting list;
- number of cadaver transplants, live transplants, new dialysis patients, failed transplant patients, dialysis mode change and deaths;
- average patient numbers by risk group for HD, PD, functioning cadaver graft and functioning live graft.

### ***Simulation input***

The parameters used in the simulation are discussed below, the following sections covering the derivation of:

Future acceptance rates	Initial acceptances
Starting prevalence (prevalence)	Patient and mode survival on dialysis
Transplant survival	Transplant waiting list
Transplant supply	Chances of receiving a transplant

### ***Future acceptance rates onto RRT***

#### ***Background***

The acceptance rate in England for RRT estimated from the 1998 Renal Survey (92 pmp) is lower than that of other developed countries; in 2000, for example, rates in Spain and Germany were 132 pmp and 175 pmp respectively. Both Wales (128 pmp) and Scotland (107 pmp) had a higher acceptance rate than England despite having smaller ethnic minority populations.<sup>2</sup> It is therefore necessary to take account of the probable increase in demand for treatment in England arising from treating current unmet need, and to take account of the ageing of the population, particularly of ethnic minorities of Indo-Asian and African-Caribbean origin because of their higher rate of renal disease.

To achieve this population, projections to 2010 for the ethnic and non-ethnic minority groups were derived separately. The recent Scottish- and Welsh-based non-ethnic minority acceptance rates were used to give some idea of the non-ethnic minority need in England. The ethnic minority rates were proportionately higher. These acceptance rates were then applied to the 2010 population estimates.

#### ***Starting population in England by ethnic minority***

Although the age and ethnic breakdown will be available from the 2001 Census, it was necessary to use the Labour Force Survey to derive this.<sup>15</sup> It shows that 85% of the White UK population, 97% of the African-Caribbean, 99% of the Indo-Asian and 97% of 'Other ethnic minorities' is resident in England. Using these figures, the numbers of the White, African-Caribbean, Indo-Asian and 'Other ethnic minority' population for England by 5 year age bands were estimated for 2000. This assumes that the age distributions for the different ethnic groups are similar in England, Wales and Scotland.

### **Projected population in England in 2010**

We had to calculate population projections by ethnic group as the available population projections for England published by the Office for National Statistics (ONS) are not broken down by ethnicity. The population of the UK in 2010 was predicted using ‘all cause mortality’ data from the ONS for 1999. The population was split into the four ethnic groups above: White, Indo-Asian, African-Caribbean and all others. Each 5 year age band from each group of the 2000 population was split equally into single years for both males and females, who then experienced the mortality for that age, and then the next year for the next age and so on for 10 years. The data were then reaggregated into 5 year age bands. Excluding migrants, the population of England in 2010 was projected to be 50.1 million, 0.3 million less than the current estimate for 2000. Including data on net migration available from ONS, the projection rises to 50.6 million; this compares well with the ONS estimated population in 2011 of 51 million.

### **Current RRT rate in England**

All scenarios need the RRT rate in England in 2000 (Table 6.1). The coverage of UK Registry of renal units in England is only partial and excludes many large units in London. It was necessary to adjust Registry data to estimate the national picture. Two methods were used.

<b>Data source</b>	<b>Renal units included</b>	<b>English Acc rate (pmp)</b>	<b>Scots Acc rate (pmp)</b>	<b>Welsh Acc rate (pmp)</b>	<b>E &amp;W Acc rate (pmp)</b>
1998 National Renal Survey	52 (all UK)	92	105	128	94.6
1999 Renal Registry	23	–	107	–	88.7
2000 Renal Registry	28	87	–	–	89

**Table 6.1: Recent data on acceptance rates for England, Wales and Scotland**

#### **Method 1 (RR)**

The simplest estimate assumes that the unit catchment populations are accurate and that the population not covered by units participating in the Renal Registry has the same age and ethnic structure as those in the Registry. We assumed, however, that the estimated unit catchment populations might be slightly inflated, and we allowed for some growth since 1998 and estimated a starting acceptance rate of 94 pmp in 2000 and a total number accepted for England of 4750. These 4750 cases were partitioned by age and diabetes by taking the actual data from the Registry for 2000 on 2101 patients, broken down by age and diabetic ERF, and scaling them up in proportion to generate the total of 4750 patients. This estimate is called ‘RR’ – an acceptance rate of 94 pmp, with 49% of patients aged over 65 and 17% having diabetic ERF (Table 6.2).

#### **Method 2 (RS)**

Method 1 may underestimate the ethnic minority pattern and total number as there were several big renal units in London with large local ethnic minority populations not contributing to the Renal Registry in 2000. An alternative approach is to use the 1998 National Renal Survey, which had an 100% response rate from all renal units,<sup>2</sup> as a basis for comparing the contributing and non-contributing units. The comparison showed that Renal Registry units contributed 40% of all acceptances in 1998. The proportion of patients over 65 was higher for Registry than non-Registry units, at 46% and 36% respectively. The proportions with

diabetic ERF were both approximately 17%. An adjusted acceptance rate was calculated using these data (Table 6.3); this gives a higher starting acceptance rate of 104 pmp (5253 cases), with 42% aged over 65 and 17% having diabetic ERF.

	18-24	25-34	35-44	45-54	55-64	65-74	75-84	>=85	Total
UKRR diabetics	1	22	50	47	92	115	32	1	360
UKRR non-diabetics	90	122	148	166	337	527	295	56	1741
UKRR total	91	144	197	212	431	643	326	57	2101
Model-derived diabetics for England	1	50	112	105	208	261	71	1	692
Model derived non-diabetics for England	205	275	335	374	765	1192	666	128	3367
Model-derived total for England	205	326	445	480	974	1454	737	128	4750

**Table 6.2: RR current acceptance scenario (UK Renal Registry-derived acceptances for 2000)**  
UKRR, UK Renal Registry.

	18-34	35-44	45-54	55-64	65-74	75+	Total
UKRR diabetics	23	50	47	92	115	33	360
UKRR non-diabetics	212	148	166	337	527	351	1741
Model adjustment factor	2.82	2.82	2.82	2.82	2.17	2.17	
Model-derived diabetics for England	64	138	130	259	251	70	911
Model-derived non-diabetics for England	599	416	467	955	1143	760	4342
Model-derived total for England	663	555	598	1214	1394	830	5253

**Table 6.3: RS acceptance rate scenario (UK Renal Registry derived using 1998 National Renal Survey)**  
UKRR, UK Renal Registry.

### ***Ethnicity***

Age-specific increased relative rates (Table 6.4) were used to derive the numbers accepted onto RRT from each age group in the two ethnic minority groups. It was assumed that ‘other’ ethnic minorities have the same risk of ERF as Whites.

Ethnic group	Age group		
	16-54	55-64	65+
Indo-Asian	3.7	6.8	7.0
African-Caribbean	3.3	5.1	7.5

**Table 6.4: Age-specific relative risk of renal disease by ethnic group**

These data were converted into age and diabetic ERF using the age ethnic and diabetic ERF pattern available from the nine units participating in the Registry in 2000 who had high completeness for these data items.

***Scenario 1: Current RR and current RS applied to the 2010 population – 103 pmp RR, 115 pmp RS***

This was used to show what growth in prevalence would occur if there were no further increase in acceptance rate over and above that arising from population change. Applying the current RR rate (scenario 1a) to the projected non-ethnic minority and ethnic minority populations for England in 2010 gives 5169 acceptances for RRT (103 pmp) in 2010, an increase of 8% on the 4750 acceptances for 2000, with 49% aged over 65 and 17% diabetic. Using the RS rate (scenario 1b), this figure rises to 5772 (115 pmp) in 2010, with 42% over 65 and 17% with diabetic ERF.

***Scenario 2: Current Scottish acceptance rates – 125 pmp***

Methods similar to those described above were used to calculate the likely RRT rate in England in 2010 if the recent acceptance rates seen in Scotland were to apply in England. The number of new patients accepted onto RRT in 2010 would be 6286, an overall rate of 125 pmp, with 51% over 65 and 18% having diabetic ERF.

***Scenario 3: Current Welsh acceptance rates – 162 pmp***

The predictions were repeated using the recent Welsh acceptance rates. This scenario estimates 8112 new cases accepted onto RRT in 2010, an overall rate of 162 pmp, 51% being aged over 65 and 17% having diabetic ERF.

***Scenario 4: Current Welsh over 45 years and current English less than 45 years – 147 pmp***

In this scenario, it is assumed that the current rate of acceptance for RRT in the younger English age groups is meeting need and will remain constant, whereas the take-on rate in older groups will increase. Scenario 4 therefore uses the higher Welsh rates in the 54+ age groups and each of the current English acceptance scenarios (RR and RS) for those less than 54 years old. This produces an acceptance rate in 2010 of 144 pmp (7234 new patients) if RR based and 147 pmp (7345 patients) if RS based.

***Scenario 5: Current Welsh acceptance rate with an estimated migrant population – 162 pmp***

This assumes that the English 2010 take-on rate will increase to that of the current Welsh rate and that the ethnic minority population will increase further to include new immigrants. With this scenario, there would be 8213 new patients accepted for RRT in 2010 (162 pmp), 50% being over 65 years old and 17% having diabetic ERF.

***Scenario 6***

This used a 2001 survey of all UK renal units undertaken by the Renal Association (John Scoble, personal communication) for the starting stock. There is an emerging epidemic of type II diabetes. The World Health Organization is predicting an increase in the prevalence of diabetes in the UK from 1.28 million in 1995 to 3.09 million in 2010.<sup>16</sup> To take account of this, data were used from a study of trends in diabetes prevalence based on the General Practice Research Database data, which found an increase of just under 20% in prevalence from 1994 to 1998.<sup>17</sup> A conservative 10% increase in the number of new patients with diabetic ERF predicted in 2010 was applied to the Welsh acceptance rate scenario; this gave a total acceptance rate of 158 pmp, 19% of whom would have diabetic ERF.



All the scenarios excluded paediatric cases (<16 years), but their rates are very low compared with those of adults (1.9 pmp in the under-16s).

### ***Starting acceptance arrays and the initial mode of therapy, by age group and diabetes status***

The starting acceptance arrays were based on the current acceptance data adjusted by the RR or RS method, as discussed, and shown in Tables 6.2 and 6.3 above broken down by age and diabetic ERF. Data on all new patients accepted onto the Renal Registry from 1997 to 2000 were used; these included age, sex, primary renal disease and timelines of all the modes of treatment and death. The proportions allocated to PD, HD or a pre-emptive transplant were derived from Registry data.

In a further scenario, to allow for a different balance of HD and PD that took account of patient choice with the wider availability of HD, the proportion of incident patients over 55 starting HD was increased by 10% in absolute terms, that for PD being similarly reduced.

### ***Prevalence of patients on RRT in 2000 at start, by age, mode and diabetes***

These were based on an extrapolation of Registry data on stock (RR method), extrapolation taking into account the 1998 National Survey (RS method) and also the use of the 2001 survey of all UK renal units (adjusted to England in 2000 with Renal Registry data being used to group patients by age and diabetes). The three starting stocks were 29,312, 33,307 and 29,400 patients respectively.

### ***Dialysis survival***

Data from international and national registries were collected to assess whether there was any evidence of an improvement in patient survival over time and also whether the UK survival figures differed from those of other countries. Survival trends in recent years appear largely to have stabilised; however, the International Dialysis Outcomes and Practice Patterns Study (IDOPPS) suggests that the survival rate on HD may be lower in the UK than in comparable European countries.<sup>14</sup> An analysis of the age- and diabetes-specific HD survival rates for the UK and European IDOPPS centres, based on confidential unpublished data, showed a significant difference in survival at 1 year. A scenario is therefore included whereby HD survival for the Welsh-based RS acceptances has been increased by the difference between the UK and European centres.

### ***Transplant graft and patient survival***

Transplant survival data by live grafts, cadaveric first grafts and cadaveric regrafts, as well as by age group, were provided by UKT. For the model, two piecewise exponential curves were fitted to each survival curve, one for early survival (up to 3 months) and one for later survival (after 3 months). Data from international and national registries were again used to assess the likely improvement in transplant survival. This showed that, following a period of initial improvement, transplant survival has been largely static over the past 10 years.

The mode of dialysis before and after transplantation for those patients returning to dialysis was examined to assess the effect of failures not returning to their pre-transplant mode. This showed that approximately 80% of HD patients returned to HD post-graft failure, whereas only 60% of PD patients returned to their initial mode. These percentages were incorporated into the model.

### ***Transplant waiting list and allocation***

#### ***Incident patients***

Data were provided by the UK Renal Registry and UKT on the proportion of those patients, by age group and diabetic ERF, starting dialysis between 1 January 1998 and 31 December 1999 who became registered on the transplant waiting list within the first year of RRT. This showed that those with diabetes were only 70% as likely to be listed as those without. This was used to calculate an age- and diabetes-specific chance of listing for transplant.

#### ***Prevalence patients***

Renal Registry data were available on the percentage of all those on RRT, by age group, who were on the active transplant waiting list at 1 January 1999. Data were available on the proportion of diabetics listed, although not by age. These data, together with Renal Registry data on the total numbers in each age and diabetic group, were used to derive a proportion listed by age and diabetes.

#### ***Previously transplanted patients***

An analysis was undertaken completed by UKT on the chances of listing for transplant following previous transplantation, by age and time since the failure of the previous graft. The proportions being relisted stabilised at around 24 months; these proportions were used in the model. There were also data on the proportion of diabetics relisted, although not by age. Despite their being less chance of relisting following a failed graft, the number involved was, however, very small, and the model assumed diabetics had the same chance of relisting as non-diabetics. Therefore all those previously transplanted were given a lower probability of going back onto the transplant waiting list compared with patients not previously transplanted.

### ***Transplant supply***

Data were provided by UKT on the number of transplants performed in the UK in 2000 by age group. A rate for England by type of transplant (cadaver or live) was estimated using data from the UKT 1990–98 Renal Transplant Audit on the proportion of total transplants by type performed by each centre. These data were used to estimate the number of live and cadaver transplants for England. Three scenarios were used (Base, UKT and Pragmatic) to estimate how transplant supply might change over time. ‘Base’ assumed no change in the number of transplants (22 pmp cadaver, 5 pmp live). The ‘UKT’ scenario used estimates from the UKT Business Case, which detailed the steps being taken to increase the number of organs available.<sup>10</sup> This was for an increase of the number of cadaver kidneys to 1540 (26 pmp), that of non-heartbeating donors to 210 (4 pmp) and that of live donors to 765 (13 pmp) in the UK. The final scenario was a less optimistic one, with only 90% of the predicted live and 65% of the predicted cadaver increase to 2005. The second and third scenarios assumed that the rate of organ availability would remain constant after 2005.

The model combined non-heartbeating and heartbeating donors and assumed the same survival.

### **Chances of transplant**

Data were provided by UKT on an analysis of the time to transplant for 3957 new patients listed for transplant in 1998–99. A risk score was developed using the factors age at listing, gender, diabetic status, ethnicity and number of previous transplants. People were then grouped into one of five categories according to their chance of a transplant. A simplified risk score, from 1 to 3, based on age group, diabetic status and whether there had been a previous transplant, was used in the simulation model.

### **Early start on dialysis**

The implications of an early start to dialysis were not modelled as no change in the current pattern is envisaged, although the model could be used to do this.

## **Results**

The simulation was run with data for the whole of England for 15 years with 10 replications. Table 6.5 summarises all the scenarios shown.

	2010 Acc rate	2010 Prevalence	2010 Prevalence (pmp)	2010 on HD	% on Dx	Average annual % HD growth	Average annual % RRT growth	% >65yrs
1a: Current RR	103	37,297	744	12,818	46	2.1	2.7	32.1
1b: Current Base RS	115	41,811	834	16,132	52	3.9	2.6	31.3
1b: Current RS	115	42,570	849	14,542	45	2.6	2.8	31.1
1b: Current UKT RS	115	42,777	853	14,489	45	2.5	2.8	31.1
2: Scots Base RS	125	42,935	856	16,953	53	4.7	2.9	31.9
2: Scots Prag RR	125	39,869	795	14,309	48	3.5	3.6	33.7
2: Scots Prag RS	125	43,704	872	15,374	47	3.3	3.1	31.7
2: Scots UKT RS	125	43,926	876	15,247	46	3.2	3.2	31.7
3: Welsh Base RS	162	47,472	947	20,076	58	7.4	4.3	32.6
3: Welsh Prag RR	162	44,499	888	16,818	51	5.9	5.2	34.2
3: Welsh Prag RS	162	48,170	961	18,343	52	5.9	4.5	32.3
8: Scoble RS	156	45,829	914	17,687	52	6.7	5.6	33.2
3: Welsh UKT RS	162	48,407	966	17,943	50	5.5	4.5	32.3
4: Eng & Wales Prag RS	147	45,781	913	16,897	49	4.6	3.7	34.2
5: Welsh & Migs Prag RS	162	48,553	958	18,621	52	6.1	4.6	32.1
6: Diabetes increase 10% (Scoble RS)	158	46,155	921	17,925	53	6.9	5.7	33.2
7: Dialysis choice (Welsh Prag RS)	162	48,045	958	19,047	51	6.5	4.4	32.3

	2010 Acc rate	2010 Prevalence	2010 Prevalence (pmp)	2010 on HD	% on Dx	Average annual % HD growth	Average annual % RRT growth	% >65yrs
9: IDDOPS survival (Welsh Prag RS)	162	50,951	1016	20,976	54	8.1	6.2	34.0

**Table 6.5: Summary of all scenarios**

Current, Scots & Welsh, current English, current Scots and current Welsh take-on rates applied to the 2010 population.

Scoble, John Scoble's 2000 starting stock with current Welsh acceptance rates applied to the 2010 population E&W, current English young (<54 years old) take-on rates and Welsh elderly (55+ years) take-on rates.

Welsh & Migs, Welsh take-on rates with migrants added to the 2010 population.

Diabetes increase 10%, John Scoble's 2000 starting stock with current Welsh acceptance rates applied to the 2010 population, with a 10% increase in all diabetic ERF.

Dialysis choice, current Welsh acceptance rates applied to the 2010 population, with a 10% increase in those aged over 55 starting RRT on HD and a 10% reduction in those over 55 starting RRT on PD.

IDOPPS, Welsh acceptance rates applied to the 2010 population with HD survival increased to that of the European centres in the IDOPPS study.

Base, current transplant supply; prag, pragmatic increase in transplant supply; UKT, UKT Business Case increase in transplant supply; Dx, dialysis.

Annual percentage increases were calculated by simply dividing the absolute percentage increase for each scenario by 10, the starting position being RR or RS as appropriate.

The confidence limits of the estimated means of treatment for England in 10 years time, given the expected variability in the acceptance and transplant rates, lie within 2.5% of the total for each mode and within 1% for the total. None of the totals is significantly different for different transplant supply rates. All the totals are significantly different from each other except where the migrant population is taken into account.

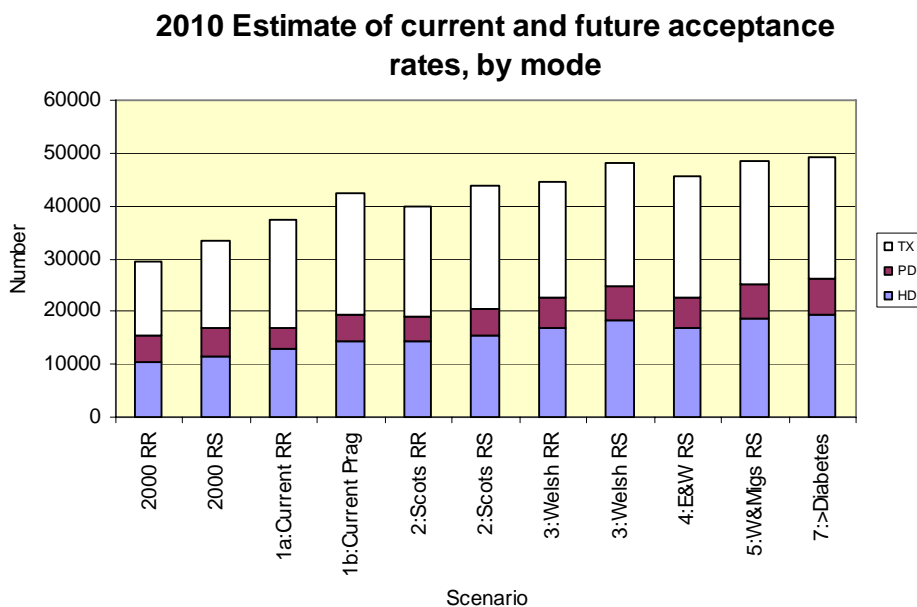

**Figure 6.2: Predicted number on RRT in 2010, by mode, for pragmatic transplant numbers**

Figure 6.2 shows the effect on future prevalence in 2010 of differences in estimating the current acceptance/prevalence rate in 2000, and of the various acceptance rate scenarios. The estimates of the starting acceptance and prevalence rates are higher using RS, and this increases the estimated future prevalence. Even if current age-specific acceptance rates apply (scenarios 1a and 1b), there will be significant growth in the demand for RRT because of population change and because a steady state has not been reached. Increasing the acceptance rate to that of Scotland or Wales (scenarios 2– 6) produces, as expected, higher growth in the future prevalence of RRT. Including ethnic minority migrants has little additional effect as they are mainly in the younger age groups. The future prevalence of RRT by 2010 is likely to lie in the region of 42,000–51,000 cases, a prevalence rate of about 850–1016 pmp. This is an average annual arithmetic growth rate of about 4.5%. Even assuming here an increase in transplant supply, the largest absolute and relative increase is in HD; the proportion on dialysis rises with the increase in the estimated acceptance rate. If patient survival on dialysis were to improve (based on the difference between the UK and European rates, using the IDOPPS data), the estimated mean number on RRT would be 50,951, with 20,976 (40%) on HD (using Welsh RS acceptance rates and the pragmatic transplant supply). Using Renal Association (Scoble) survey data for starting prevalence gives a future estimated number of 45,829. Increasing the incidence of diabetic ERF by 10% by 2010 with Scoble’s starting prevalence indicates 46,155 patients.

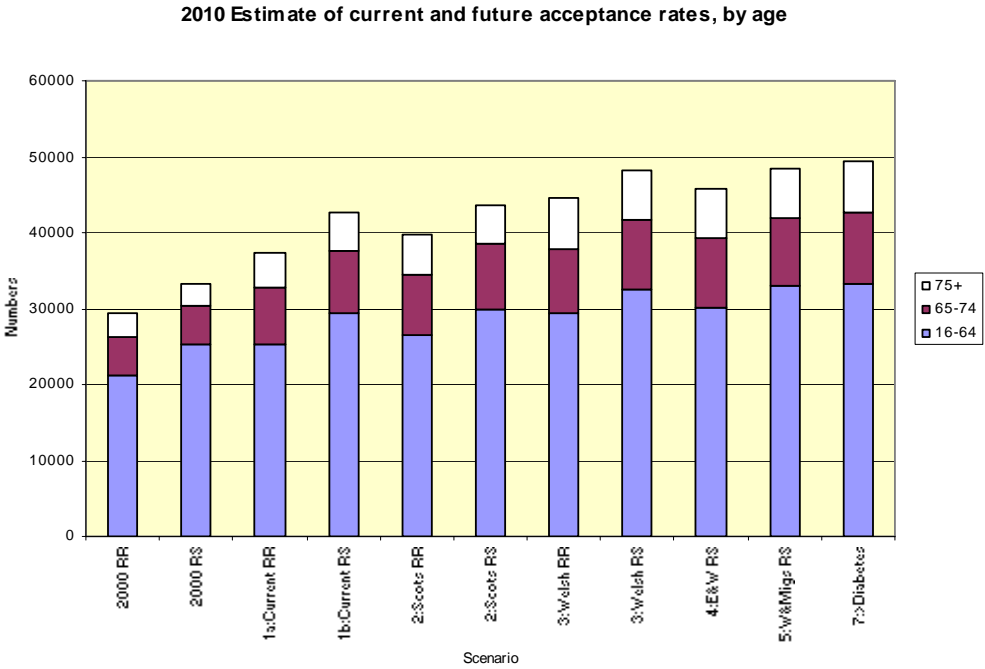

**Figure 6.3: Predicted number on RRT in 2010, by age, for pragmatic transplant numbers**

Figure 6.3 shows the age breakdown for these scenarios. The proportion over 65 increases in all scenarios similarly from 24% (RS) or 28% (RR) to about a third, the absolute numbers increasing even more steeply. It is, for example, estimated that the starting number of patients on RRT over 65 is 7920 (RS) or 8148 (RR). Using the scenario Welsh acceptance rate/RS current acceptance rate/pragmatic transplant rate, the number of patients on RRT aged over 65 is estimated to be 15,648 in 2010.

Figure 6.4 estimates the future number on RRT in 2010 for changes in transplant supply for three acceptance rate scenarios (1b, 2 and 3). Achieving the UKT-targeted increase in donor organs by 2005 does not significantly affect the total number but reduces the proportion on dialysis. In scenario 3, for example, the proportion falls from 58% if there is no increase in transplant supply to 50% if the plan is achieved, a difference of over 3000 patients on dialysis. Transplant supply has little effect on age distribution.

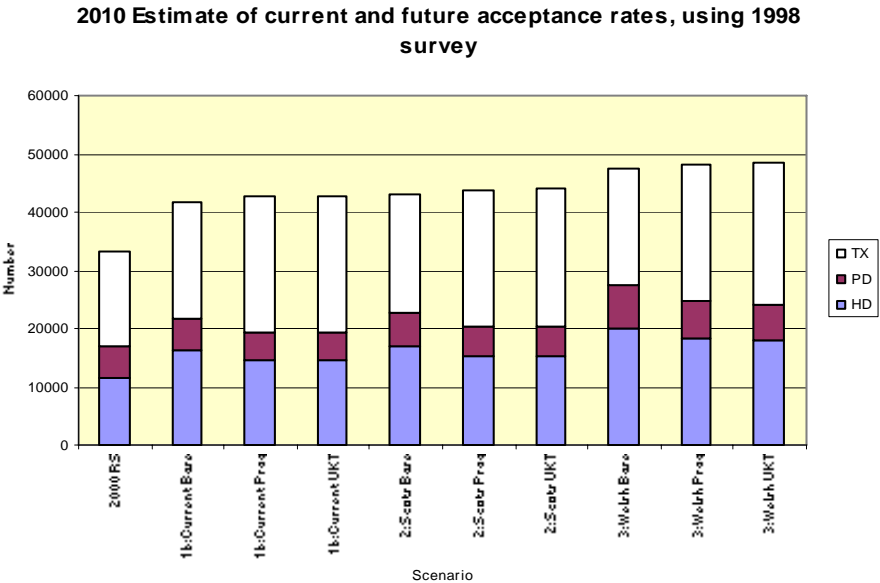

Figure 6.4: Predicted number on RRT in 2010, by mode, using the RS starting prevalence

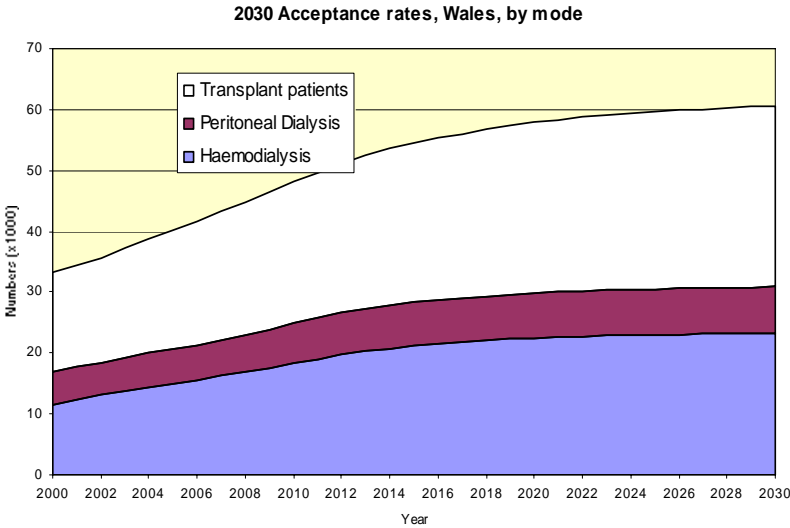
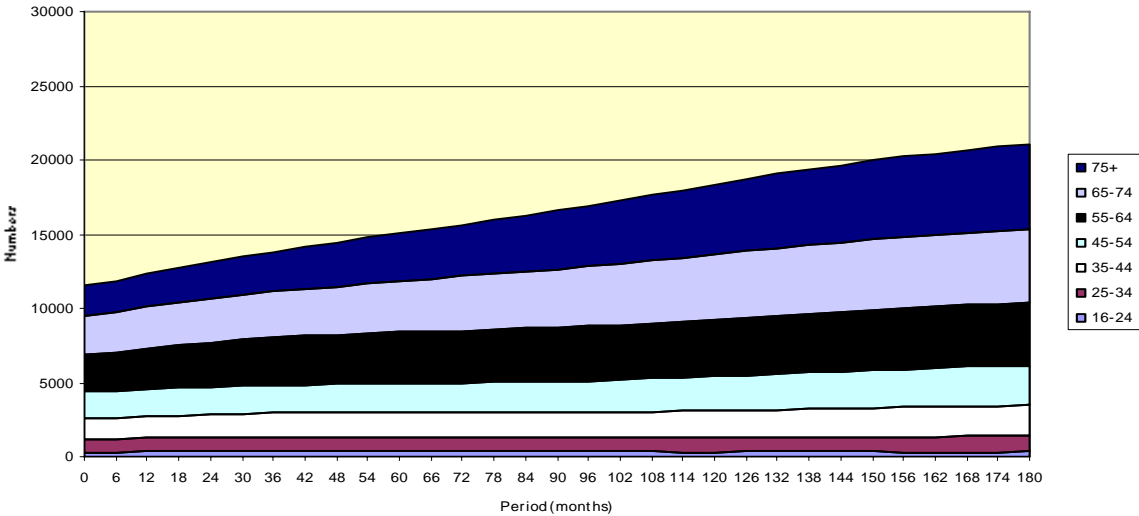

Figure 6.5: Predicted number on RRT in 2030 for Welsh acceptance rates, by mode, RS starting rate and pragmatic transplant supply

Figure 6.5 shows, using scenario 3 (Welsh acceptance rate, RS current acceptance rate and pragmatic transplant rate), the impact of running the model for longer than 10 years, on the assumption that all parameters stay the same after 2010. RRT growth continues, albeit at a declining rate, so that by 30 years the total number of RRTs is nearly 60,000 patients, and beyond that time a steady state appears to be reached. Even projecting the current acceptance scenarios, the steady state number would approach 50,000 patients.

Figures 6.6 and 6.7 show how the age structure changes differently for HD and transplants over a 15 year follow-up, again highlighting the increase in the number of elderly individuals

2015, Acceptance rates, Wales, HD, by age



on HD.

Figure 6.6: Predicted number on HD, by age, up to 2015 for Welsh RS scenarios with pragmatic transplant increase

Figure 6.7: Predicted numbers with transplant, by age, for Welsh RS scenarios with pragmatic transplant increase

2015, Transplant, acceptance rates by age, Wales

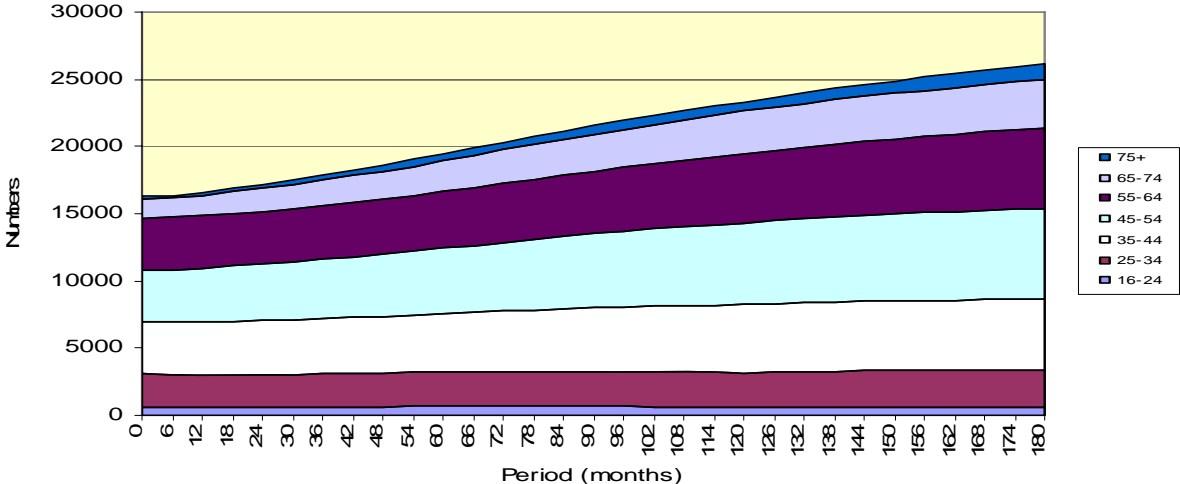

The effect of increasing the proportion starting HD where patients have a choice of modality (scenario 8) is to increase the growth rate in HD from 5.9% to 6.5% and the number on HD in 2010 from 18,342 to 19,047, other factors being equal.

## ***Discussion***

A previous discrete event simulation model, which was used in the mid-1990s to predict demand for RRT, has been rewritten. It now allows for transfers between HD and PD, includes live transplants and models realistic acceptance rate scenarios that allow for meeting current and future population need to 2010.

The model has a user-friendly Windows interface. Input data may be entered and saved for use in different scenarios. The simulation, now easy to use for national and regional scenarios, may describe the treatment and transfer of thousands of patients, and the output data may be saved on a spreadsheet and analysed using Excel. The parameters have been derived mainly from the UK Renal Registry and UKT.

The scenarios presented so far are the first stage of using the model to evaluate future demand. Others scenarios are being worked on, and more will be possible as new data emerge, not least from the UK Renal Registry as national coverage is achieved.

### ***Impact of changing acceptance rates***

Even without any increase in the current acceptance rate, the demand for RRT will continue to rise as a steady state has not yet been reached. Moreover, future population changes alone may increase the incidence of ERF; it is estimated the acceptance rate would change for RR from 94 pmp to 103 pmp, and for RS from 104 pmp to 115 pmp by 2010 as a result of such changes.

A more realistic scenario is, however, that there will be an additional increase in acceptance rate to treat unmet need, which will lead to a large increase in RRT, predominantly caused by an increase in HD, with a commensurate increase in cost. For example, the Welsh acceptance rate scenario with a pragmatic increase in transplant supply predicts, by 2010, a prevalent number of 48,000 patients. The types of patient (in terms of age and diabetic ERF) also change, not, however, in proportion but in absolute number. For the same scenario, the increase in those aged over 65 between 2000 and 2010 would be a doubling from 8,000 to nearly 16,000; the number on HD would increase from about 11,600 to 18,300.

We do not know what future acceptance rates will be. Our estimates are based on the current Welsh rate, and the future need for treatment may prove to be different from that, but the age rates used in the Welsh scenario are similar to those of European countries with high rates (Figure 6.8). We do not currently even know exactly what the current rates are. A clearer picture should emerge from the Registry over the next few years as coverage increases.



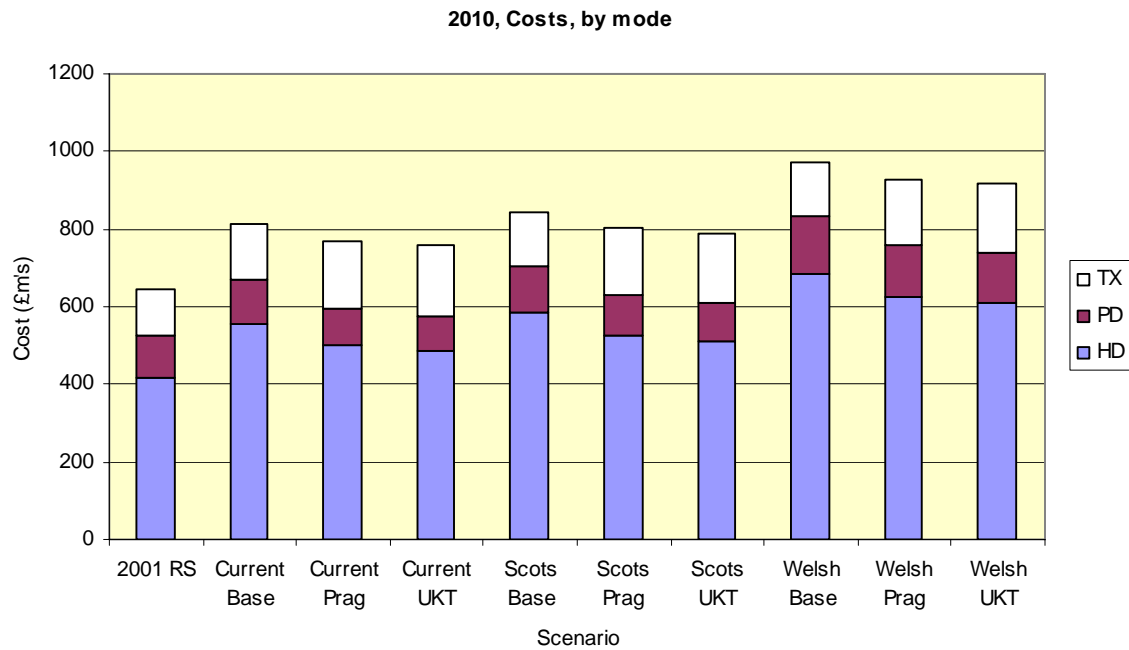

**Figure 6.8: Take-on rate pmp by age and country in 2000**

### ***Diabetic ERF***

There is a substantial variation in the estimated acceptance rate for diabetic ERF in developed countries, from under 10 pmp to over 100 pmp. This is the result of several factors: the variation in the underlying epidemiology of diabetes (largely type II), the effectiveness of the health care system in preventing diabetic nephropathy, referral/acceptance patterns and the classification and coding of diabetic ERF. The Scottish and Welsh acceptance rates increase the diabetic ERF rate from the current 17 pmp seen in England. Furthermore, the estimates take account of the ageing of the population, particularly in the ethnic minority groups, which will cause the amount of diabetic ERF to rise in absolute terms.

It is predicted that there will be a substantial rise in the incidence and prevalence of type II diabetes over the coming decades. The key question is whether the transition to ERF can be prevented or reduced by more effective management and, by implication, whether the rate of diabetic ERF can be reduced, even given this larger pool of diabetic patients. There is good evidence that progression can be reduced by tight glucose control, control of hypertension and specifically the use of angiotensin-converting enzyme inhibitors. Most countries are, however, seeing a rise in the diabetic ERF rate with the increased incidence of diabetes. This, together with the probable unmet need in diabetics, may on balance prevail and drive the ERF rate up. Furthermore, improvements in survival in patients at high risk of death (e.g. by reducing cardiovascular risk) would potentially have a big impact on demand. We have used conservative estimates of the increase in diabetic nephropathy (a 10% increase in all ages); the impact on the total number receiving RRT was minimal at this level, in part because of poorer patient survival in those with diabetic ERF.

### ***Transplant supply***

Increasing the transplant supply as targeted by UKT did, as expected, change the number and proportion of patients with a transplant by 2010. The difference between no change and achieving the plan was, for example, a reduction in the proportion on dialysis from 58% to 50% (using Welsh RS scenario 3). Because of the demand from the existing waiting list and the increased input from the rising acceptance rate, organ supply would, however, still be insufficient. Taking the Welsh RS scenario as an example, the transplant waiting list would increase from 4228 to 5224.

The proportions on different modes of therapy are clearly affected by transplant supply. The predominant mode of treatment, even with the transplant increase, would be HD. Reductions in graft failure through the use of more effective immunosuppression would also reduce the proportion on dialysis. The National Institute of Clinical Excellence is reviewing immunosuppression to take account of newer agents such as mycophenolate; again, this issue can be considered using the model.

The model does not currently factor in ethnic minority group directly and therefore has not been able to explore the mismatch between supply and demand for cadaver transplants in this group.

### ***Conclusion***

In summary, this national model has demonstrated that there will continue to be substantial growth in the RRT population in England, estimated to be over 45,000 patients by 2010. This is due to several factors:

- an increasing prevalence arising from past changes, even in projecting a constant acceptance rate until a steady state has been reached;
- projections of an increased take-on rate to meet estimated population need in England (using extrapolation from other countries);
- the impact of demographic change;
- the increasing numbers of type II diabetes patients;
- improving patient survival.

The total pool is significantly influenced by the expected acceptance rate. This highlights the importance of implementing strategies to prevent the incidence and progression of chronic kidney disease; the National Service Framework for Renal Disease will begin to address this. There is preliminary evidence from the Scottish Renal Registry that the acceptance rate has flattened after the continuous rises seen in the 1980s and first half of the 1990s. Even so, there is still likely to be a substantial increase in demand even if current acceptance rates do stabilise. Transplant supply does have an impact on the dialysis to transplant ratio, but, even with an optimistic projection of the future supply, there is still likely to be a substantial increase in the demand for HD, especially in the elderly.

Further issues need to be explored: the cost of RRT, changes in patient and mode survival, including the impact of comorbidity, the effect of newer immunosuppressive regimes on graft survival, and the use of acceptance rates from other countries with higher rates.

Given the uncertainty related to several of the parameter estimates, the model needs to take account of new evidence on trends in demographic and outcome data. These should be forthcoming from the UK Renal Registry with the recruitment of all renal units and as more follow-up time is available. The model can be used at regional and sub-regional level, although any difference in local parameters will have to be taken into account.

## Acknowledgements

We are very grateful to Professor Dirk Jacobus van Schalkwyk and Dr David Ansell from the UK Renal Registry, and Mr Chris Rudge, Rachel Johnson and Phil Pocock from UK Transplant, for their help with and advice over relevant data. We thank Ron Pisoni from the IDOPPS group for unpublished data on HD survival, and Dr Jon Scoble for national survey data.

## REFERENCES

1. UK Renal Registry. *UK Renal Registry Report 2001*. Bristol: UK Renal Registry, 2001.
2. UK Renal Registry. *UK Renal Registry Report 2000*. Chapter 3: 1998 National renal survey. Bristol: UK Renal Registry, 2000.
3. Roderick P, Raleigh VS, Hallam L, et al. The need and demand for renal replacement therapy in ethnic minorities in England. *J Epidemiol Comm H* 1996;50:334–9.
4. Roderick P, Clements S, Diamond I, et al. Estimating demand for renal replacement therapy in Greater London: the impact of demographic trends in ethnic minority populations. *Health Trends* 1998;30:46–50.
5. Department of Health. *Diabetes National Service Framework: Setting Standards*. 2001. [www.doh.gov.uk/nsf/diabetes](http://www.doh.gov.uk/nsf/diabetes).
6. Davies R, Roderick P. Predicting the future demand for renal replacement therapy in England using simulation modelling. *Nephrol Dial Transplant* 1997;12:2512–16.
7. Davies R, Davies HTO. Modelling patient flows and resource provision in health systems. *Omega Int J Manage Sci* 1994; 22: 123– 31.
8. Roderick P, Ferris G, Feest T. The provision of renal replacement therapy for adults in England and Wales: recent trends and future directions. *QJM* 1998;91:581–7.
9. UK Transplant. *Transplant Activity Report 2000*. Bristol: UK Transplant, 2001.
10. UK Transplant. *More Transplants – New lives: Business case to the Department of Health, England and the Health Departments in Scotland, Wales and Northern Ireland*. Bristol: UK Transplant, 2001.
11. Renal Registry. *UK Renal Registry Report 2001*. Chapter 3: National survey of renal satellite units in England & Wales. Bristol: UK Renal Registry, 2001.
12. Little J, Irwin, A, Marshall, T, et al. Predicting a patient’s choice of dialysis modality: experience in a UK renal department. *Am J Kidney Dis* 2001; 37: 981– 6.
13. Renal Association. *Treatment of Adult Patients with Renal Failure*, 2<sup>nd</sup> edn. London: Royal College of Physicians, 1997.  
Pisoni RL, Young EW, Combe C, et al. Higher Catheter Use within Facilities is Associated with Increased Mortality and Hospitalization: Results from DOPPS [Abstract]. San Francisco; American Society of Nephrology, 2001.  
Office for National Statistics. *The Quarterly Labour Force Survey*. London: ONS; 2001.  
Amos AF, McCarty DJ, Zimmet P. The rising global burden of diabetes and its complications: estimates and projections to the year 2010. *Diabet Med*. 1997; 14: S7– 85.  
Newnam A, Ryan R, Kunti K, Majeed A. Prevalence of diagnosed diabetes mellitus in general practice in England and Wales 1994– 98. *Health Stat Quart* 2002;14:5–13.  
Briggs JD, Berthoux F, Jones E. Predictions for future growth of ERF prevalence. *Kidney Int*. 2000; 57(suppl 74): 46–48.  
Branley P, McNeil JJ, Stephenson DH, Evans SM, Brigant EM. Modelling the future dialysis requirements under various scenarios of organ availability in Australia. *Nephrology* 2000;5:243– 9.  
Xue JL, Mas JZ, Louis TA, Collins AJ. Forecast of the number of patients with end-stage renal disease in the United States to the year 2010. *J Am Soc Nephrol* 2002;12:2753– 8.